

Pallet handling

pallet magazine
Page 6





Karl H. Bartels GmbH
Max-Planck-Straße 6
25358 Horst (Holstein)
Phone: +49 4126 3968 0
Fax: +49 4126 3968 68

info@bartels-germany.de
www.bartels-germany.de

Our brochures



Rack systems



Tilting container



Stair climber



Sebastian Krayenborg
Managing Director



Henrik Valentin
Sales and marketing manager

TECHNICAL CONSULTANTS



OLIVIA EGGERS

Phone: +49 4126 39 68 -251
Fax: +49 4126 39 68 -269
eggers@bartels-germany.de



MARIE LENDOWSKI

Phone: +49 4126 39 68 -262
Fax: +49 4126 39 68 -269
lendowski@bartels-germany.de



MARC MEYER

Phone: +49 4126 39 68 -255
Fax: +49 4126 39 68 -269
Mobil: +49 178 71 80 484
mmeyer@bartels-germany.de

PALLET HANDLING

MAGAZINE • CHANGER • TURNERS



- Consulting, planning, production and assembly from one source
- Implementation of your individual storage requirements
- Our short internal processing time ensures a fast reaction even to short-term changes

IHR YOUR PALLET HANDLING

We support you in optimizing your workflow.



Pallet magazine

Palomat Flexomatic.....	6
Palomat Green Line.....	7
Palomat Type 5.....	7
DStacker pallet magazine	8

Pallet changer / turner

PalletX Pallet changer	9
Pallet turner 95°.....	10
Pallet turner 180°.....	11

Pallet handling

Pneumatic positioning table / rotary table	12
Platform lift table	13
Pallet stacking system PSS.....	14-15
Pallet pull-outs for shelves	16-19
Pallet truck	20
Pallets.....	22-23



Pallet magazine - no more manual lifting of pallets

- Avoidance of injuries
- Reduction of sick days per employee
- Order and improvement of working
- Optimised pallet flow and increased efficiency
- Saving costs for pallet handling
- Avoidance of manual pallet handling
- Reduction of time consumption per pallet
- Reduced need for forklift travel

Automate pallet handling for all pallet types (wood - steel - plastic)



Design: PLC control: Siemens S7-1200, energy: 6-8 bar (except Greenline type) and 230 V, lubrication/maintenance-free, paint: standard colours RAL 3002 - 5002 - 7032 - 7035
The pallets can be inserted and removed with hand pallet trucks, electric stackers and forklifts.

All pallets are handled at floor level.
The warranty for a PALOMAT is 1 year or 1800 working hours.



Pallets
You will find on page 21

- 3002
- 5002
- 7032
- 7035



Type Flexomatic

Fully automatic stacking and destacking of empty pallets one after the other. Switching between stacking and destacking by operating the touch panel.

Dimensions L x W x H	Safety barrier	Capacity	Pallet size	Loading capacity	Item-No.	Price / piece
mm		Stück	mm	kg		€
935 x 1450 x 2350	inclusive	15	600 x 800 x 150	500	404.341	9545,00
1520 x 1340 x 955	no	15	1200 x 800 x 150	500	404.326	6900,00
1520 x 1540 x 955	no	15	1200 x 1000 x 150	500	404.327	7100,00
1520 x 1340 x 2350	inclusive	15	1200 x 800 x 150	500	404.328	7750,00
1520 x 1540 x 2350	inclusive	15	1200 x 1000 x 150	500	404.329	7950,00
1520 x 1340 x 3750	inclusive	25	1200 x 800 x 150	800	404.330	9700,00
1520 x 1540 x 3750	inclusive	25	1200 x 1000 x 150	800	404.331	9990,00



Palomat® for 15
pallets
with lateral
Safety barriers

Without compressed air, only a power outlet is required!



Type Greenline



Fully automatic stacking and destacking of empty pallets one after the other.
Switching between stacking and destacking by operating the touch panel.

On request: Also available for cold rooms with temperatures down to -25°C - please ask!

Dimensions L x W x H	Safety barrier	Capacity	Pallet size	Loading capacity	Item-No.	Price / piece
mm		Stück	mm	kg		€
935 x 1450 x 2350	inclusive	15	600 x 800 x 150	500	404.342	10545,00
1520 x 1340 x 955	no	15	1200 x 800 x 150	500	404.332	7900,00
1520 x 1540 x 955	no	15	1200 x 1000 x 150	500	404.333	8100,00
1520 x 1340 x 2350	inclusive	15	1200 x 800 x 150	500	404.334	8750,00
1520 x 1540 x 2350	inclusive	15	1200 x 1000 x 150	500	404.335	8950,00
1520 x 1340 x 3750	inclusive	25	1200 x 800 x 150	800	404.336	11500,00
1520 x 1540 x 3750	inclusive	25	1200 x 1000 x 150	800	404.337	11800,00



Palomat@ for 15 pallets with lateral Safety barriers

Type Palomat@ 5



Half-automatic stacking and unstacking.

Choose the Palomat@ 5 if you want to stack and destack up to 5 pallets simultaneously and if you only want to use electricity as an energy source. Operation via the touch panel.

On request: Also available for cold rooms with temperatures down to -25°C - please ask!

Dimensions L x W x H	Safety barrier	Capacity	Pallet size	Loading capacity	Item-No.	Price / piece
mm		Stück	mm	kg		€
1520 x 1340 x 2350	inclusive	15	1200 x 800 x 150	500	404.343	13325,00
1520 x 1540 x 2350	inclusive	15	1200 x 1000 x 150	500	404.344	13625,00
1520 x 1340 x 3750	inclusive	25	1200 x 800 x 150	800	404.345	14850,00
1520 x 1540 x 3750	inclusive	25	1200 x 1000 x 150	800	404.346	15200,00



Palomat@ for 25 pallets with lateral Safety barriers

Accessories for every Palomat@



Forklift protection

Type	Item-No.	Price / pair
		€
of 10 mm thick steel	404.338	405,00



Light mast incl. min/max detector

Type	Item-No.	Price / pc.
		€
Light pole incl. Max-detector	404.340	700,00



Min/Max-detector

Typ	Item-No.	Price / pc.
		€
Max-detector Greenline	404.339	350,00
Max-detector Flexomatic	404.347	350,00



Your Palomat@:

Manufactured - to fit your pallet size.

Please contact us!

Pallet magazine

For high pallet turnover during picking

Pallet magazine

- Optimal in picking with walkie riders/ pickers
- Fast pallet output: Depending on model 1 pallet every 10 sec.
- Designed for high pallet turnover
- Easy and fast refilling by forklift truck
- Reduced space requirement for pallet handling
- Side windows allow visual inspection of the mechanics

Quick removal of the pallets:

1. The operator moves his picker under the first pallet and lifts the entire stack minimally.
2. Then the fork is lowered again and the desired pallet is already on the forks. The driver can now drive to the place of use.
3. After leaving the picker, the pallet magazine lowers the pallet stack back to the floor and is ready for the next pallet removal.

The DStacker is a revolutionary pallet magazine that works without electricity, pneumatics or hydraulics. Innovative technology that minimizes the CO2 footprint.



Pallet magazine			
Pallet capacity	pc	50	65
	Item-No.	346.170	346.171
Price / piece	€	on request	on request



Pallet change

Pallet changer

- Depending on the model, up to 80 pallet changes per hour
- No more „overhead turning“ of the pallet
- More efficient and safer than conventional pallet changing systems
- Space-saving due to minimum usable area
- Can be operated by one person

Design: Two versions available.

Model 1 clamps with two plates, by means of compressed air, inflexible goods such as cartons or rigid containers without damaging them.

For more flexible and heavier goods, Model 2 is used, which clamps the goods on all four sides and is operated with combined compressed air and electricity.



Pallet changer		Model 1	Model 2
	Item-No.	346.172	346.173
Price / piece	€	on request	on request

Palett turner



Change pallets quickly and safely

- Change pallets quickly and safely
- Replace damaged goods quickly
- Simply turn products 90° or 180°
- Fast and user-friendly operation
- Increase in productivity
- Standard and special designs possible
- Inline and in connection with pallet handling systems applicable
- Cost reduction of rental pallets through shorter periods of use and avoidance of shrinkage
- Can also be used outdoors

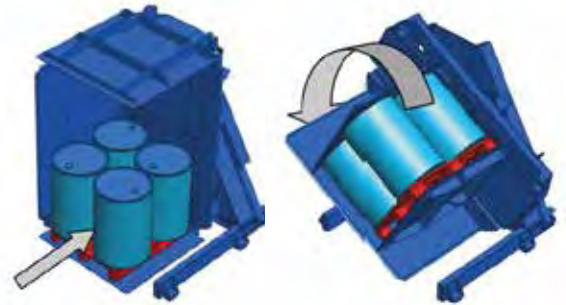

Palett turner 95°

- Cost-effective entry-level model
- Can be loaded at ground level with pallet truck and forklift
- Time saving due to short swivel procedure
- Ideal when goods must maintain their position (barcode)

Design: The 95° pallet turner clamps with a guide plate and turns 95 degrees.

Suitable for: Fixed containers such as crates, frozen products, For boxes and for sacks and big bags please use a 180° pallet turner.

Palett turner 95°		
Loading capacity	kg	max. 1500
Opening	mm	from 800 to 2000
	Item No.	346.138
Price / piece	€	on request



Freezer Spacer

- Ideal for food processing, in blast freezing applications
- or in supply chain applications for cold stores
- Reduction of energy costs through fast freezing
- Ideal for export, as it is light and inexpensive
- Made of HDPE material that prevents product slippage and is resistant to most chemicals
- Stackable

Design: Perfect spacers for chilled goods. Spacers are 100% recyclable, easy to clean and reusable.

Product tabs at the corners to reduce movement of the housing or product.

Freezer Spacer		
Load capacity	kg	1630
	Item No.	346.145
Price / piece	€	on request

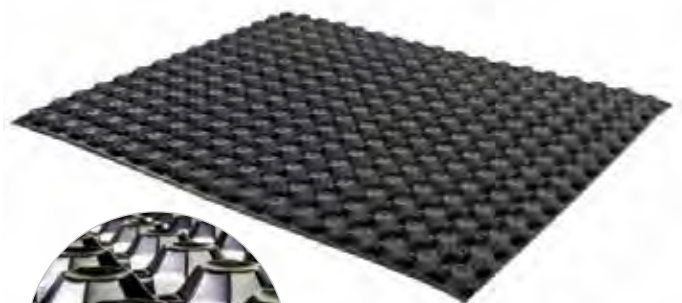



Pallet turner 180°

Loading - Turning - Emptying

- Pallets and goods are transported from above and below with uniform Pressure fixed
- Ideal for sensitive goods
- Can be loaded at ground level with pallet truck and forklift via ramp
- Pressure of the clamping tables optionally adjustable

Design: The 180° pallet turner can due to its double clamping plates, can take loads with large size variations of 650 mm to 2,000 mm. For larger or smaller product dimensions please contact us.

Suitable for: All product and packaging types



Pallet turner 180°		
Loading capacity	kg	max 2000
Opening	mm	from 650 to 2000
	Item No.	346.137
Price / piece	€	on request

For all models we can offer a version for deep-freeze storage down to -40°C.

You can find further explanations and devices on our homepage www.bartels-germany.de

All machines can be manufactured according to customer requirements.

Ergonomic working with the Positioning table - always the right working height

Robust
Steel construction

Central rotation axis for gentle,
smooth turning - prevents
uneven rotation

Self-damping - none
Shock absorber necessary

Load weight compensation
- Surface of the load is always
at comfortable, ergonomic working
height

Pneumatic by means of compressed
air working air spring
- different loads advantageous
controllable

Simple adjustment for different
Replace loads without springs

Sturdy steel base frame,
no additional assembly

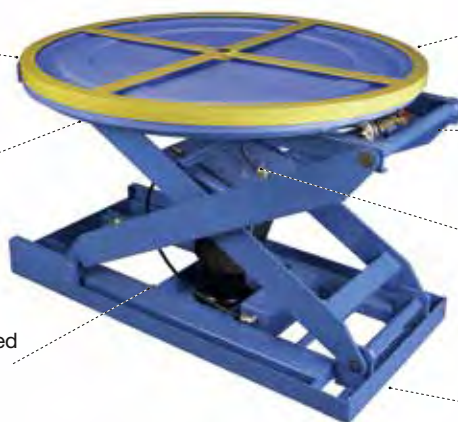

Pneumatic positioning table

- For ergonomic working
- Automatic levelling to the correct working height - it lowers when loading and raises again when unloading.

Design: Robust scissor lift table construction that requires hardly any maintenance. The lifting force is pneumatically controlled by means of an air bellows is regulated. It has a carousel platform that allows the loads to be rotated to any desired location to ensure easy loading and unloading within easy reach. It is free-standing and can be used in any location.

For indoor use with an operating temperature of - 1° C - + 48° C. Supplied with complete valve unit and pressure gauge. Platform 360° rotatable. Function without permanent compressed air connection, mechanical springs or energy supply. Colour: RAL 5015 sky blue, RAL 1018 zinc yellow.

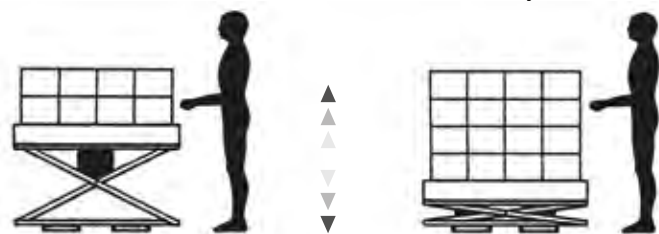

Height regulating - always at the right working height



Optional with bellows

	Type	EZ-40	EZ-50
Load capacity	kg	min. 130 - max. 1400	min. 430 - max. 2000
Overall height, lowered	mm	267	267
Overall height, raised	mm	775	775
Rotary table Ø	mm	1092	1092
Base frame L x W	mm	1245 x 617	1245 x 617
Weight	kg	172	172
	Item No.	317.064	317.065
Price / pc.	€	3064,00	3364,00

Accessories

Type	Item-No.	Price / pc.
		€
Bellows for EZ-40 / EZ-50	317.066	670,00
Square platform 1300 x 1100 mm	317.067	650,00
Square platform 1650 x 1200 mm	317.068	725,00
Increase for electric pallet trucks	317.069	550,00
Closed, round platform	317.070	395,00

Rotary table

Load capacity 2000 kg

- Easy, manual turning of heavy loads
- Loading and unloading of pallets on conveyor belts,
- Roller and roller conveyors

Design: Solid steel construction, turntable with closed platform and ball bearings; colour: light blue RAL 5012.

Load capacity	kg	2000
Rotary disk Ø	mm	1000
Length	mm	1000
Width	mm	1000
Height	mm	600
Weight	kg	120
	Item No.	129.002
Price / pc.	€	1444,00



Item-No. 129.002

Platform lift table
 with open or closed platform

- Healthy back“ campaign seal of approval
- Manufactured according to the Machinery Directive and EN 1570
- Purely hydraulic safety edge
- 400 Volt version, 230 Volt on request
- Hydraulic power unit with protective cover and quick coupling
- Platform width for Euro pallets and mesh pallets (industrial pallets on request)
- With e-platform for pallet truck loading or with closed Table platform with drive-up wedge as accessory
- All-round footwell clearance without disturbing floor frame
- Quick assembly and commissioning due to delivery ready for operation
- Also available in special sizes, stainless steel and explosion-proof design - please enquire!



Type F-CE

Design: Robust design with full steel scissors and platform made of ST 52. hydraulic power unit with protective cover and quick coupling, platform width for Euro pallets, industrial pallets and for mesh pallets. Cylinder impact-protected underneath the platform. With safety protection / deflector bar on the platform with emergency stop function.

Type FE: Platform recess designed for pallet trucks and walking stackers.

Type F-CE: With closed platform.

Please indicate design when ordering:

- stationary version with fixed point bearing for dowel fastening in the ground or as
- mobile version with four floor rollers

	Type	FE			F-CE			
		300/75	600/75	1200/75	300/75	500/75	1000/75	1500/75
Load capacity	kg	300	600	1200	300	500	1000	1500
Lifting height	mm	750	750	750	750	750	750	750
Effective stroke	mm	680	680	670	680	680	670	670
Overall height	mm	70	70	80	70	70	80	80
Platform length	mm	1300	1300	1300	1450	1450	1450	1450
Platform width	mm	910	910	910	900	900	900	900
Lifting time	sek	20	20	25	20	20	25	30
Motor 400	Volt	400	400	400	400	400	400	400
	Item No.	331.152	331.158	331.151	331.160	331.161	331.162	331.167
Price / pc.	€	3100,00	3450,00	3800,00	2960,00	3100,00	3240,00	3380,00



Type FE



Type FE



Type FE

Accessories

Ramp wedge



Rotary platform



Container tilting device up to 25° inclination

Extra charge	Item No.	Price / pc.
Ramp-up wedge, foldable, 400 mm long, for type F-CE	331.155	315,00
Rotary platform	331.165	On Request
Container tilting device	331.166	On Request

Pallet Stacking System PSS STACK LOADED PALLETS!



The PSS pallet stacking system ensures optimum utilisation of truck space through flexible height adjustment, enabling up to 600% more loading capacity.

- Suitable for all EPAL pallets
- Stackability of goods of different heights
- Plannable space utilisation in the truck
- Loading of different products
- Optimized use of the payload
- Easy handling during loading
- Optimized weight distribution
- Removal of the goods from all sides
- Production to customer-specific dimensions possible (Standard are dimensions of EPAL pallets)
- Safe loading according to the standard

Design: Material: Corner assemblies made of steel, electrogalvanised and side profiles made of aluminium. Scope of delivery consists of a complete system without pallet.

Dimensions folded 1900 x 125 x 390 mm.
Max. Stacking height approx. 2250 mm. 4-fold stackable.

On request: Production according to customer-specific dimensions is possible (standard are dimensions of EPAL pallets). Side parts can be labelled according to customer specifications at an extra charge.

Please note the lot size of 5 pieces!



This picture shows the PSS folded up. The different height settings on the corner pillars are clearly shown.

PSS for full truck space utilization

Max. 3 PSS next to each other in the truck width

	Type	PSS
Min. height from ground	mm	394,5
Max. Height from the ground	mm	554,5
Useful height between 2 pallets min / max	mm	330 / 490
Useful height between 2 pallets when used as empty frames	mm	980
Usable pallet dimensions*	mm	1160 x 760
Weight	kg	14,9
	Item No.	336.100
Price / piece	€	332,00

*The snap-in hooks of the contact surface slightly reduce the inner dimension at the four corners.

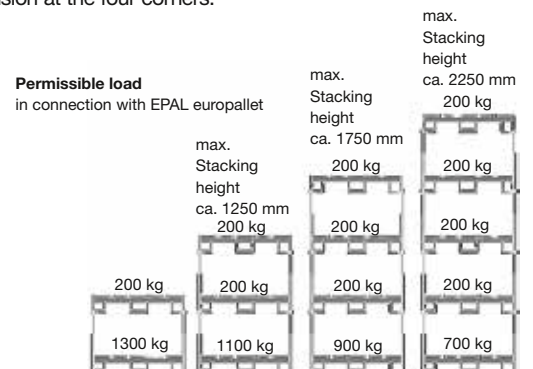

Pallet Stacking System PSS for KLT containers

WITH FOLDABLE PALLET STORAGE AREAS

With the PSS pallet stacking system for KLT containers, these can be placed to fit 100% of the pallet size.

By folding up the pallet support, the containers can be easily inserted and removed again.

- 100 % utilisation of the pallet area
- 2-fold telescopic
- Stackable up to 4 systems
- Variable use of the pallet area possible with different KLT containers

Design: Material: steel, galvanized and side profiles made of aluminium.

	Type	PSS - KLT
for pallets	mm	1200 x 800
Load capacity	kg	max. 1500
Min. usable height	mm	260
Max. usable height	mm	470
Dimensions when folded L x W x H	mm	1900 x 315 x 353
Weight	kg	17,9
	Item No.	336.102
Price / piece	€	382,00

Please note the lot size
of 5 pieces!



Pallet Stacking System PSS-RAHMEN

STACKING SOLUTION FOR PALLETS WITH STACKING FRAMES

- Products on the pallet remain accessible (loading and unloading)
- Reduction of parking space
- Simple assembly - place corners on the frame and lock it with the clamping mechanism
- For all common stacking frames

Design: Material: galvanised steel.

At a height of 500 mm, struts must be installed between the individual corners for transport safety and stability (are included in the delivery).

1 set consisting of 4 PSS FRAME corners.

	Type	PSS - RAHMEN		
Height	mm	250	350	500
for pallets	mm	1200 x 800	1200 x 800	1200 x 800
Load capacity	kg	1000	1000	1000
Braces		-	-	inkl.
Weight	kg	7,2	9,6	16,5
	Item No.	336.103	336.104	336.105
Price / Set	€	185,00	219,00	270,00

Please note the lot size of 5 pieces!



A lot of Flexibility due to tiered pallet drawers

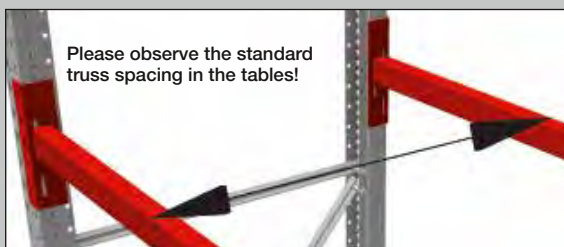

Load capacity of the pallet rack:

For single-sided pull-out, the front cross member must have a higher load capacity than the drawer load. These cross beams must be designed for these forces. If necessary, this can be obtained from the supplier of the pallet rack.

Regular concrete screws are not sufficient for fixing and can be replaced by ground anchors.

The basic rule is:

Only one drawer per field (several drawers on top of each other) may be pulled out at a time.

Inserted drawers must be securely locked. The pallet rack must be anchored to the floor. The cross beams must be bolted to the frame.

Truss load - All load capacities are valid with evenly distributed load!

Type	Load capacity	approx. extract	Min. load per truss			
			L = 900/950 mm	L = 1350 mm	L = 1800 mm	L = 2700 mm
UE-370	300 kg	70%	836 kg		1168 kg	1500 kg
UE-670.2	700 kg	70%	1856 kg		2592 kg	3328 kg
UE-870	800 kg	70%	2108 kg		2946 kg	3784 kg
UE-17415	1000 kg	62%	2476 kg		3514 kg	4552 kg
UE-17404	600 kg	62%	1880 kg		2668 kg	3456 kg
UE-17420	600 kg	70%		1656 kg		2352 kg
UE-17425	1000 kg	65%		2926 kg		3322 kg
UE-17430	600 kg	70%		1608 kg		2224 kg
UE-17435	1000 kg	62%		2476 kg		3514 kg
UE-16601	300 kg	100%	1256 kg		1622 kg	1988 kg
UE-16601-L	300 kg	100%		1196 kg		1596 kg
UE-16604	600 kg	100%	2108 kg		2878 kg	3548 kg
UE-16604-L	600 kg	100%		2184 kg		2952 kg
UE-16606	1000 kg	100%	3548 kg		4628 kg	
UE-16606-L	1000 kg	100%		3516 kg		4688 kg
UE-16675	600 kg	70+70%	1704 kg		2364 kg	3024 kg
UE-16675-L	600 kg	70%		1740 kg		2394 kg
UE-16875	800 kg	62+62%	2092 kg		2952 kg	3812 kg
UE-16875-L	800 kg	62%		2232 kg		3086 kg
UPK-8012	300 kg	70%	852 kg		1188 kg	1524 kg
UPK-8012. 100	200 kg	100%	808 kg		1060 kg	1312 kg
UPK-8012-L	300 kg	70%		864 kg		1236 kg

Pull-Out System for Pallets

For mounting on cross beams in pallet racks or directly on the ground



- Converts a pallet rack into a drawer rack
- Suitable for almost all standard pallet racks
- Convenient access to the goods from 3 sides, without the need for a pallet truck or forklift
- Ergonomic, back and shoulder-friendly working positions
- Space saving possible due to smaller aisle widths
- Safety through pull-out stop

Design: Solid, proven steel construction with load-bearing components, high-quality ball bearing guides, Delivery including mounting material. Pallet stops are mounted at the rear and are supplied loose for the front part. Standard colour blue RAL 5010, other colours as shown possible, but delivery time will be extended by 3 weeks.



5010 2012 9002 7016 9006

On request: Other colours available for an extra charge and other dimensions possible - please ask!

Unilateral Extension - Basic model

extendible 62 - 70%

Type	Load Capacity	Extension	For Rack Depth	Storage Area W x D	Overall Width	Height	Standard Crossbeam Distance, external - external	Item No.	Price per piece with 10 units*
	kg		mm	mm	mm	mm	mm		
UE-370	300	840 mm	1100	830 x 1240	880	85	990-1123	356.949	276,00
UE-17420	600	590 mm	800	1230 x 900	1280	85	700-800	356.944	356,00
UE-17430	600	840 mm	1100	1030 x 1240	1080	85	990-1123	356.954	373,00
UE-670.2	700	840 mm	1100	830 x 1240	880	85	990-1123	356.950	295,00
UE-870	800	840 mm	1100	830 x 1240	880	85	990-1123	356.948	338,00
UE-17415	1000	760 mm	1100	830 x 1240	880	85	990-1123	356.951	338,00
UE-17425	1000	590 mm	800	1230 x 900	1280	85	700-800	356.945	369,00
UE-17435	1000	760 mm	1100	1030 x 1240	1080	85	990-1123	356.955	387,00



Unilateral Extension - Basic model

extendible 100%

Type	Load Capacity	Extension	For Rack Depth	Storage Area W x D	Overall Width	Height	Standard Crossbeam Distance, external - external	Item No.	Price per piece with 10 units*
	kg		mm	mm	mm	mm	mm		€
UE-16601	300	1240 mm	1100	830 x 1240	875	100	1000-1123	357.628	450,00
UE-16601-L	300	840 mm	800	1230 x 900	1275	100	700-800	357.629	468,00
UE-16604	600	1200 mm	1100	830 x 1240	875	100	1000-1123	356.953	513,00
UE-16604-L	600	840 mm	800	1230 x 900	1275	100	700-800	357.655	530,00
UE-16606*	1000	1200 mm	1100	830 x 1240	880	120	1000-1123	356.929	636,00
UE-16606-L*	1000	840 mm	800	1230 x 900	1280	120	700-800	357.656	655,00

*The minimum order quantity for the product is 10 pieces

Mountable Pull-Out System for Pallets

fitting for meta pallet racks



Mountable Pull-Out System for Pallets

Low Construction Height - Direct Installation on Pallet Racks

- Drawers are installed directly on the pallet rack frame. Since no crossbeams are needed a lot of shelf height is conserved.
- Transforms a pallet rack into a drawer rack
- Suitable for almost all commercially available pallet racks
- Convenient access to or into pallets or boxes without a hydraulic-trolley or forklift
- Ergonomic operating posture enabled, no acrobatics and athletic amount of force required
- Safety brake in closed position, is unlocked by a handle (accessories)
- Optionally, one or both sides extensible

Design: The established, robust steel construction with supporting components of outstanding quality is made of high-strength steel. Delivery includes mounting materials (as well as angular stops and ball-bearing mounted guides). Pallet stop are supplied separately for the front and back. Default color is blue RAL 5010, other colors, as shown, are available but will be extend the delivery time by 3 weeks.



5010 2012 9002 7016 9006

Please technical information see page 16

Matching stands for these drawers offer will be pleased to send you a copy on request.

Unilateral Drawer - Basic Model

pulls out up to 62-70%

Design: Equipped with ball bearings at the sides. The frame of the pallet rack must be screwed to the floor. A crossbeam is installed in max. 2000 mm height to guarantee the appropriate lateral support and width.

Supplied with handle 350 mm.



Type	Load Capacity	Extension	For Rack Depth	Storage Area W x D	Overall Width	Height	Item No.	Price per piece with 8 units*
	kg		mm	mm	mm	mm		€
UE-18460	700	840 mm	1100	840 x 1240	950	25	357.631	441,00
UE-18360	1000	760 mm	1100	840 x 1240	950	25	357.633	441,00
UE-18360-L	1000	675 mm	800	1240 x 960	1350	25	357.661	466,00

*The minimum order quantity for the product is 8 pieces

Unilateral Drawer - Basic Model

pulls out up to 100%

Design: Equipped with ball bearings at the sides. The frame of the pallet rack must be screwed to the floor. A crossbeam is installed in max. 2000 mm height to guarantee the appropriate lateral support and width.

Supplied with handle 350 mm.

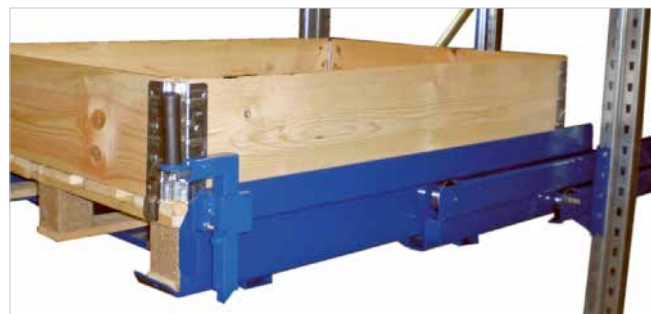

Type	Load Capacity	Extension	For Rack Depth	Storage Area W x D	Overall Width	Height	Item No.	Price per piece with 8 units*
	kg		mm	mm	mm	mm		€
UE-17660	500	1200 mm	1100	825 x 1240	950	60	357.630	556,00
UE-17680	800	1200 mm	1100	825 x 1240	950	60	357.632	606,00
UE-17680-L	800	840 mm	800	1225 x 960	1350	60	357.662	627,00
UE-16690	1000	1200 mm	1100	825 x 1240	950	60	357.663	692,00
UE-16690-L	1000	840 mm	800	1225 x 960	1350	60	357.664	705,00

*The minimum order quantity for the product is 8 pieces



Mounting: On the floor on rails, including handle.

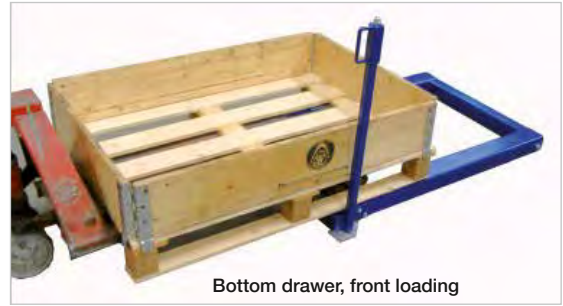

Bottom drawer, front loading

Floor Drawer with rail guidance

- Load side = Extension side. Open model - ideal for loading the by hydraulic trolley
- Handle on the right side with locking function
- Manually controlled

Loading from the front

Type	Load Capacity	Extension	For Rack Depth	Storage Area W x D	Overall Width	Height	Height Handle	Item No.	Price per piece with 10 units*
	kg		mm	mm	mm	mm	mm		€
UV-16695-2-420	1000	1050 mm	1100	800 x 1200	840	70	420	357.650	352,00
UV-16695-2-620	1000	1050 mm	1100	800 x 1200	840	70	620	357.651	352,00
UV-16695-2-800	1000	1050 mm	1100	800 x 1200	840	70	800	356.958	352,00

Loading from the back

Type	Load Capacity	Extension	For Rack Depth	Storage Area W x D	Overall Width	Height	Height Handle	Item No.	Price per piece with 10 units*
	kg		mm	mm	mm	mm	mm		€
UV-16695-1-420	1000	1050 mm	1100	800 x 1200	840	70	420	357.652	352,00
UV-16695-1-620	1000	1050 mm	1100	800 x 1200	840	70	620	357.653	352,00
UV-16695-1-800	1000	1050 mm	1100	800 x 1200	840	70	800	356.957	352,00

*The minimum order quantity for the product is 10 pieces

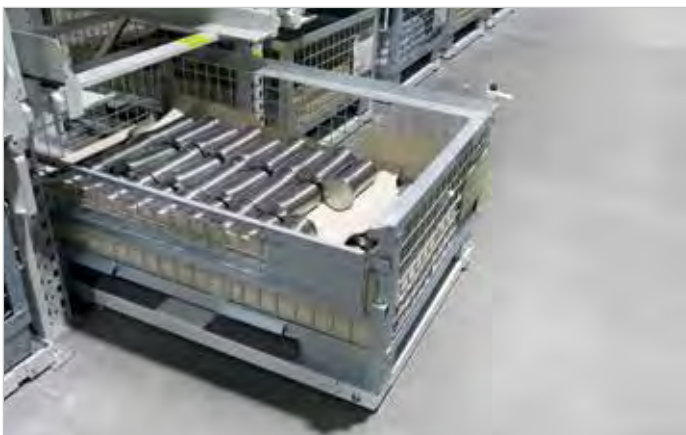

Flexi-Pallet Truck, Hydraulic pallet truck

Flexi-Pallet Truck width adjustable

- Ideal for the transport of: crates, machine tools, cabinets, barrels, pallets, etc.
- Mechanical lifting system appreciated by removal companies



Design: Wheels: 2 front wheels Ø 75 mm and 2 swivel castors Ø 125 mm.

On request: Delivery also possible with 1000 kg load capacity, please enquire!

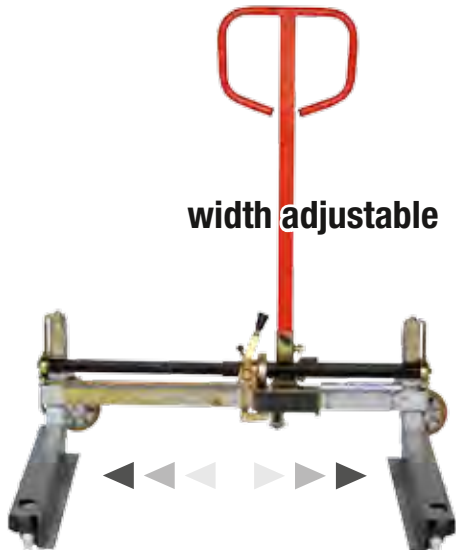

width adjustable



Type	Load capacity	Width	clear tine spacing	Fork length	Fork height min./max.	Lifting height	Weight	Item No.	Price / piece
	kg	mm	mm	mm	mm	mm	kg		€
LEV PAL-BAC 58	750	555 - 975	400 - 800	825	2,5 / 75	103 / 180	40	302.240	1715,00
LEV PAL-BAC 59	750	555 - 975	400 - 800	1025	2,5 / 75	103 / 180	46	302.241	1837,00

Hydraulic pallet truck with 2500 kg load capacity

- Optionally with solid rubber or polyurethane tyres
- Overload protection as standard

Design: Robust, durable welded steel construction, hydraulics with galvanized housing, piston hard chrome plated. High-quality wheel equipment, optionally with solid rubber or polyurethane tyres. Nylon overrun rollers as standard. Colour: yellow, drawbar black

	Type	GP 250	GP 251
Load capacity	kg	2500	2500
Steering wheels	mm	Polyurethan Ø 200 x Breite 50	Vollgummi Ø 200 x Breite 50
Tandem-Fork rollers	mm	Nylon Ø 82 x Breite 68	Nylon Ø 82 x Breite 68
Fork length	mm	1150	1150
Fork width A/A	mm	540	540
Lifting range	mm	85 - 195	85 - 195
Weight	kg	86	86
	Item No.	300.016	300.033
Price / piece	€	293,00	293,00



Item No. 300.016

Item No. 300.033

Pressed wood pallet

Compression-moulded from recycled wood

- Low cost
- No rental costs
- No exchange fees
- Space saving in stocking

Environment

A resource-saving recycling product, biologically degradable, materially or thermally easily recyclable.
 PEFC-certified - The wood comes from sustainably managed forests and controlled sources.
 Further information: www.pefc.de

Please indicate the batch size when ordering of 25 pieces!

Handling

- Low own weight
- Stable and safe for transport
- Multiple use possible
- Therefore shrink and stretch friendly
- Protection of your cargo by closed bottom side

Air freight

- Low pallet weight
- Very tamper-proof due to closed bottom side

Export

- IPPC-ISPM15-konform – processed wood
- Export certificates free of charge for China, Australia, USA, Mexico, Turkey, etc. Suitable formats for ISO overseas containers



From an order quantity of 50 pieces we grant a special discount of 7,5%!

Display and transport pallets in EURO formats

Type	Dimensions L x W	Load capacity	Entry height	Entry height	Weight	Item No.	Price / piece
	mm	kg	mm		ca. kg		€
F 44	400 x 600	250	95	2-seitig	2,5	339.041	8,11
F 36	400 x 800	500	95	2-seitig	4,5	339.043	8,84
F 36(s)	800 x 400	1000	95	2-seitig	4,5	339.044	10,51
F 64	600 x 800	500	95	4-seitig	5,0	339.046	9,40
F 64(s)	600 x 800	1000	95	4-seitig	5,5	339.047	10,79
F 8LF	800 x 1200	900	97	4-seitig	10,5	339.050	11,53
F 8LF (s)	800 x 1200	1250	97	4-seitig	11,5	339.051	13,40

Container and export pallets

Type	Dimensions L x W	Load capacity	Entry height	Entry height	Weight	Item No.	Price / piece
	mm	kg	mm		ca. kg		€
F 76	760 x 1140	900	97	4-seitig	11,0	339.078	11,47
F 76(s)	760 x 1140	1250	97	4-seitig	11,9	339.079	12,91
F 11	1140 x 1140	900	97	4-seitig	14,0	339.080	15,00
F 11(s)	1140 x 1140	1250	97	4-seitig	18,0	339.062	16,80
F10/2	1200 x 1000	900	97	4-seitig	14,5	339.053	15,07
F10/2(s)	1200 x 1000	1250	97	4-seitig	17,0	339.054	16,80

Pallets



Nestable Stacking pallet with 6 or 9 feet

- Can be accessed from 4 sides, underclearance 100 mm
- Space-saving storage, because stackable

Design: No sirenx treatment, resistant to chemicals, fully recyclable, easy to clean, weather resistant, nailable. 6 or 9 single feet, sliding edge outside; colour: grey/anthracite.

On request: Part no. 339.027 also available without sliding edge - please specify when ordering!

Dimensions L x W x H	Load capacity, static	Load capacity, dynamic	Los-size	Weight	Item No.	Price / piece
mm	kg	kg	Stk.	kg		€
800 x 600 x 145	1000	500	20	7	339.025	19,33
1200 x 800 x 155	1000	500	19	13	339.027	26,20
1200 x 1000 x 145	1000	500	20	14	339.028	29,07



Art. no. 339.003 and 339.004 also available with non-slip edge - please specify when ordering.

Plastic Recycling pallet with 3 longitudinal blades

- Without backslash
- Chemical, UV and weather resistant
- Fully recyclable, nailable
- Easy to clean - Suitable for food

Design: Closed deck area, accessible from 4 sides, Runners tacked, entry height 100 mm; colour: grey/anthracite.

On request: Article no. 339.003 and 339.004 also available with anti-slip edge - please specify when ordering!

Dimensions L x W x H	Load capacity, static	Load capacity, dynamic	Los-size	Weight	Item No.	Price / piece
mm	kg	kg	Stk.	kg		€
1200 x 800 x 145	3000	800	15	25	339.003	51,07
1200 x 1000 x 145	3000	800	15	27	339.004	56,13
1140 x 1140 x 140	3000	800	17	25	339.005	57,56



Version with blades



Version with feet

Plastic four-way pallet with runners and with feet

- Suitable for roller and chain conveyors
- Pallet with skids for high-bay storage
- Pallet with feet stackable into each other

Design: Sturdy made of PE-RE material; underclearance 100 mm. Colour: Anthracite.

Please note the lot size of 10 pieces!

Type	Dimensions L x W x H	Load capacity, static	Load capacity, dynamic	Load capacity on the shelf	Weight	Item No.	Price / piece
	mm	kg	kg	kg	kg		€
Kufen	1200 x 800 x 160	4000	1200	400	18,5	339.109	50,00
Füße	1200 x 800 x 145	4000	1200	-	15,5	339.108	33,00
Kufen	1200 x 1000 x 160	4000	1200	400	19,5	339.559	54,00
Füße	1200 x 1000 x 145	4000	1200	-	16,5	339.554	34,00



Version with 3 blades



Version with 9 feet

Universal plastic pallet

- Retractable on 4 sides, without anti-slip edge
- Version with 9 feet or 3 runners available
- Closed upper deck, easy to clean

Design: Made of PE-RE material, underclearance 100 mm; temperature resistant from -40° to +70°C. Colour: Grey.

On request: Also available with anti-slip edge!

Please note the lot size of 20 pieces!

Type	Dimensions L x W x H	Load capacity, static	Load capacity, dynamic	Load capacity on the shelf	Weight	Item No.	Price / piece
	mm	kg	kg	kg	kg		€
Kufen	1200 x 800 x 155	6000	2500	500	25	339.095	60,00
Füße	1200 x 800 x 140	5000	1500	-	19	339.558	52,00

Heavy duty plastic pallet completely enclosed design



Special and heavy duty versions possible!
Please contact us!

- Closed upper and lower deck
- With 3 runners and anti-slip edge

Please specify the batch size of 10 pieces note!

Design: Made of PE-RE material, runners welded iron reinforcement in upper deck. Colour: Grey.

Dimensions L x W x H	Load capacity, static	Load capacity, dynamic	Load capacity on the shelf	Weight	Item No.	Price / piece
mm	kg	kg	kg	kg		€
1200 x 800 x 150	7500	2500	1250	29	339.555	86,00
1200 x 1000 x 150	7500	2500	1250	35	339.556	101,00



Heavy duty plastic pallet with Anti-slip coating completely enclosed design



Please specify the batch size of 10 pieces note!

- Ideal for extreme applications
- To ensure safe transport and a damage-free goods cycle
- With non-slip mat firmly pressed in over the entire surface

Design: Made of PE-RE material with closed deck surface, firmly pressed-in anti-slip mat, extremely robust due to iron reinforcement of the upper deck and the firm welding of the upper deck and the runners. Retractable on 4 sides, temperature resistance from -30°C to +70°C. Colour: Grey.

On request: Other formats, anti-slip edge and a Anti-slip coating on the underside of the pallet is possible - please enquire!

Dimensions L x W x H	Load capacity, static	Load capacity, dynamic	Load capacity on the shelf	Weight	Item No.	Price / piece
mm	kg	kg	kg	kg		€
1200 x 800 x 150	7500	2500	1250	34	339.566	102,00
1200 x 1000 x 150	7500	2500	1250	40	339.567	120,00



Item No. 339.566



Item No. 339.567

Plastic pallet stacking frames Splinter-free and stackable

- Practical packaging system
- Simple handling
- Ideal for all common pallets in Euro dimensions
- Conversion of the existing pallet stock not necessary
- Folded, space-saving storage and cost-effective empty transport
- Safe and efficient transport and storage protection
- Can be used as a closed unit with Lid (optional - please order separately)
- Hygienic, weather-resistant alternative to wooden stacking frames.

Design: Very stable, shatterproof, durable top frames made of ABS plastic with interlocking reinforcements; smooth inner sides; high stability under side loads. Max. load 600 kg. Colour: Black.



Type	Dimensions	Weight	Item No.	Price / piece
	mm	kg		€
4 Hinges	400 x 600 x 200	3	339.600	39,00
4 Hinges	600 x 800 x 200	3,7	339.601	46,00
6 Hinges	600 x 800 x 200	3,7	339.602	54,00
Lid	600 x 800	1,5	339.605	28,00
4 Hinges	800 x 1200 x 200	5,5	339.022	52,00
6 Hinges	800 x 1200 x 200	6	339.023	59,00
Lid	800 x 1200	3	339.024	48,00
4 Hinges	1000 x 1200 x 200	6,2	339.603	60,00
6 Hinges	1000 x 1200 x 200	6,7	339.604	70,00



Please order cover separately!

Our brochures



Our main catalogue



KARL H. BARTELS GmbH

Max-Planck-Straße 6
25358 Horst/Holstein - Germany
Phone: +49 4126 3968 -333
Fax: +49 4126 3968 -68

info@bartels-germany.de
www.bartels-germany.de
www.bartels-shop.com