

# DRUM LOADING DEVICE

## TECHNICAL SPECIFICATIONS

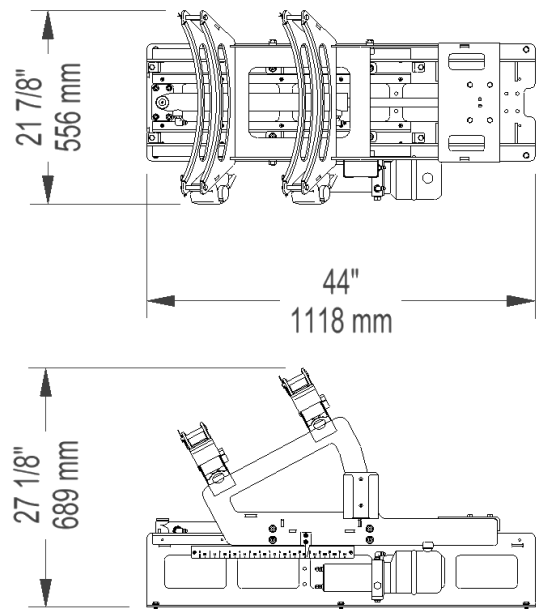
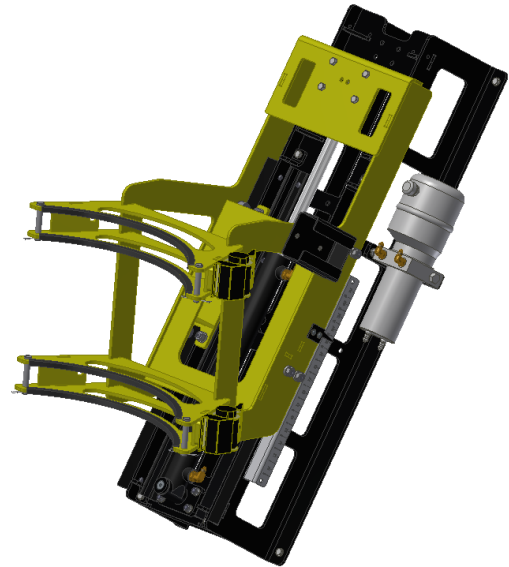
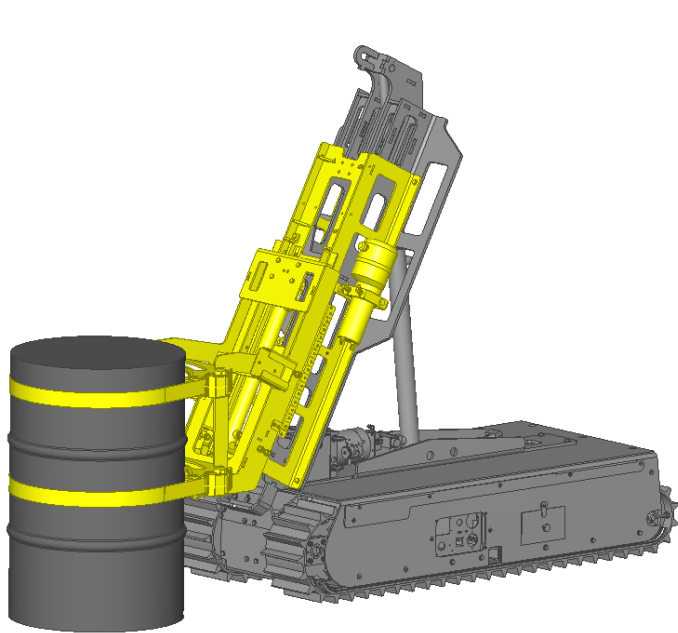

### PHYSICAL CHARACTERISTICS

Material	Aluminum and steel	
Model	- Manual - Hydraulic	
Length	44 in	1118 mm
Width	21 <sup>7</sup> / <sub>8</sub> in	556 mm
Height	27 <sup>1</sup> / <sub>8</sub> in	689 mm
Weight	110 lb (man.) 140 lb (hyd.)	50 kg (man.) 64 kg (hyd.)
Load bearing capacity* (inclined surface)	650 lb at 40°	295 kg at 40°
Load bearing capacity* (on stairs)	650 lb at 40°	295 kg at 40°
Load bearing capacity* (flat surface)	650 lb	295 kg

### COMPATIBLE WITH :

- Lifting device

\* These load bearing capacities have been tested with a Twin-Track 66 model. Contact your dealer to know the load bearing capacities of this accessory when it is used with other Track-O models.

The information contained in this document is subject to change without notice.