

# RECHARGE STATION FOR BATTERIES

## TECHNICAL SPECIFICATIONS

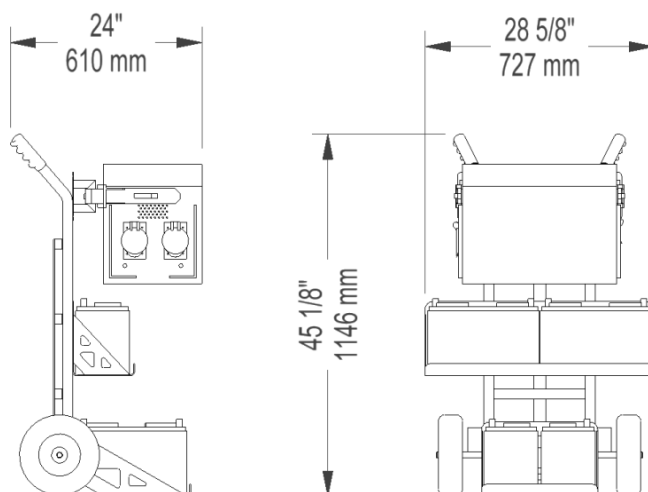
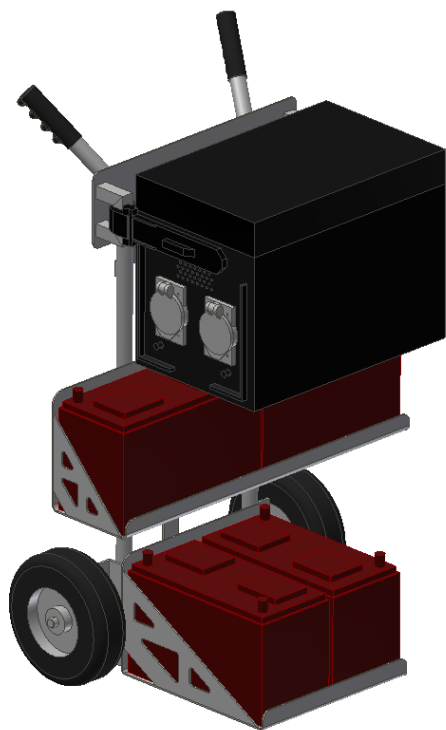

### ELECTRICAL CHARACTERISTICS

Batteries amperage / voltage*	85 - 115 - 130 A @ 12 VDC (x4)
Charger	Integrated AC-DC (x2)
AC input voltage (charger)	85 à 265 VAC
AC input current (charger)	12 A @ 120 VAC 5 A @ 230 VAC
AC input frequency (charger)	45 à 65 Hz
Battery recharging time* (pair)	5.5 à 8.5 hours approx.

### COMPATIBLE WITH :

- Twin-Track 47
- Twin-Track 66
- Heavy-Duty
- Cross-Country

### PHYSICAL CHARACTERISTICS

Material	Steel	
Length	24 in	610 mm
Width	28 5/8 in	727 mm
Height	45 1/8 in	1146 mm
Weight (each battery)	66 lb	30 kg
Weight (case)	50 lb	23 kg
Weight (trolley)	50 lb	23 kg

\* The battery model depends on the Track-O model. Contact your dealer to know the characteristics concerning the batteries installed in your Track-O.

*The information contained in this document is subject to change without notice.*