

SCISSOR LIFT TABLE

CAP. 1000 LB – 24" RUN

TECHNICAL SPECIFICATIONS

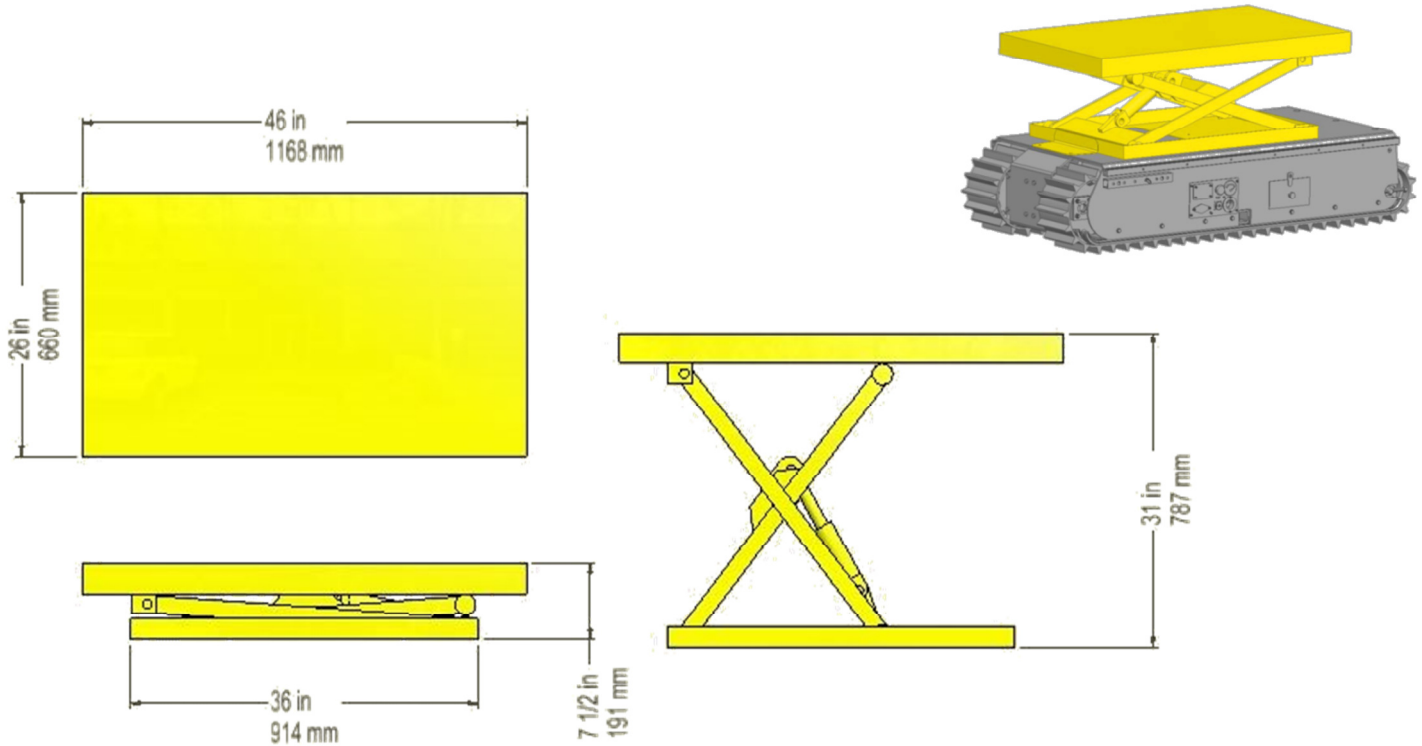

PHYSICAL CHARACTERISTICS

Material	Steel	
Length (platform)	46 "	1168 mm
Width (platform)	26 "	660 mm
Length (base)	36 "	914 mm
Width (base)	24 "	610 mm
Platform height (lowered)	7 1/2 "	191 mm
Platform height (elevated)	31 "	787 mm
Run	23 1/2 "	596 mm
Weight	330 lb	150 kg
Lifting capacity	1000 lb	454 kg

POWER FEATURES

Hydraulic unit	24 VDC
Control	- Wired (standard) - Wireless (option)

COMPATIBLE WITH :

- Twin-Track 47
- Twin-Track 66
- Heavy-Duty
- Cross-Country

The information contained in this document is subject to change without notice.